

Concept and Development of Fpga Calculation and Control Method of Dependant Temperature

Chakradhar Karan¹, Srinibash Swain²

¹ Department of electrical Engineering ,Gandhi Engineering College , Odisha ,India

² Department of electrical Engineering ,Gandhi Institute For Technology, Odisha ,
India

ABSTRACT: This paper presents an efficient FPGA based VLSI system to measure the temperature and keep the system at a constant temperature. The RTD (resistance temperature detector) Pt100 is used as a temperature sensor, and is interfaced with the FPGA (XC3S400) manufactured by Xilinx. The output that is produced by the sensor is connected to the signal conditioning circuit, which convert the output into quantized voltage levels in order to send it as an input to an ADC. The necessary code is written in the hardware description language VHDL. ISE (Integrated Simulation Environment) version 9.1i suite is used for software development which is one of the EDA (Electronic Design Automation) tool offered by the Xilinx Company.

Keywords: FPGA, ADC, RTD Pt100, LCD, Relay.

I. INTRODUCTION

Temperature is among the most frequently measured analog parameters. This might be expected since most electrical, chemical, mechanical, and environmental systems are affected by the temperature directly or use its value to control other relevant process [1]. The design performed here uses Xilinx Spartan-3 (XC3S400) FPGA, Platform Flash PROM(XCF02), JTAG for Boundary scan mode, Temperature sensor (RTD Pt100), Low Power Quad Operational Amplifier(LM324), ADC(AD574), Auto Ranging 4 ½ Digital Multimeter (SM5011A) and a 2-lines/16-characters liquid crystal display (LCD), Electromagnetic Relay. The block diagram of the hardware developed in the present work is shown in Fig.1.

Temperature sensors play a pivotal role in many measurements and other integrated microsystems. Different types of sensors like, RTD, thermocouples, thermistors, thermostat, solid state sensors, IC sensors etc., are used in different applications [2]. Thermocouple and RTD sensors are adequate for most high-temperature measurements, but one should choose a sensor that has characteristics best suited for the application.

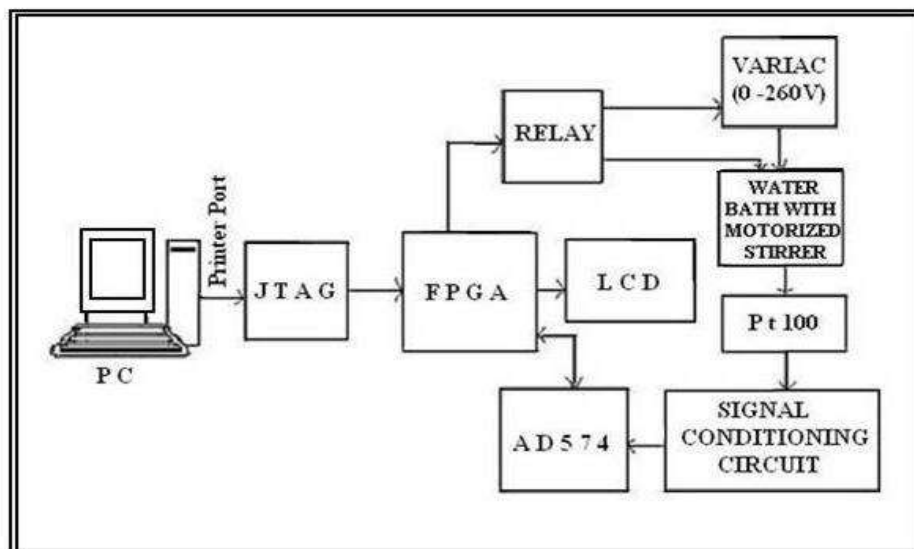

Fig.1. Block diagram of FPGA based temperature measurement & control system

II. DESCRIPTION OF THE HARDWARE DETAILS

WATERBATH WITH MOTORIZED STIRRER

The Photograph of the water bath with motorized stirrer is shown in Fig.2. The water bath contains a vessel with 3/4th of water, Stirrer and a heating element. The vessel is kept in a wooden box and the top is also

closed with insulating cap. A small 'L' shaped iron rod is attached to the DC motor shaft, which acts as stirrer. The DC motor is fixed on the top of the wooden box. Here the stirrer is used for getting the uniform temperature in the water bath. The Pt100 sensor and probes of the digital thermometer are also dipped in the bath through the holes beside the DC motor on the top of the wooden box. When power is ON, DC motor gets energized to rotate along with the stirrer is also rotated to get the uniform temperature throughout the experiment.



Fig.2. Waterbath with motorized stirrer

RTD & SIGNAL CONDITIONING CIRCUIT

RTD resistance is proportional to temperature, applying a known current through the resistance produces an output voltage that increases with temperature. Knowledge of the exact relationship between resistance and temperature allows calculation of a given temperature. The change in electrical resistance vs. temperature of a material is termed as the "temperature coefficient of resistance" for that material. RTDs offer high precision and an operating range of -200°C to $+850^{\circ}\text{C}$. They also have an electrical output that is easily transmitted, switched, displayed, recorded, and processed using suitable data-processing equipment. Moreover, an RTD is the most stable, accurate, and linear device available for temperature measurement [3]. The resistivity of metal used in an RTD (including platinum, copper, and nickel) depends on the range of temperature measurements desired. The nominal resistance of a platinum RTD is 100 at 0°C . RTD Pt100 in the form of wire wound design is used as a temperature sensor, because it gives values of better accuracy, linearity and long-term stability. A two-wire lead resistance compensating technique is adopted in using the Pt100. In order to obtain the exact temperature, it is of paramount importance to avoid self heating of the sensor, which means that the current passing through the sensor should be held low. The voltage drop across the Pt 100 is in the order of micro or mill volt [4]. This voltage is amplified suitably using the linearizing and signal conditioning circuit developed in the laboratory as shown in Fig. 3.

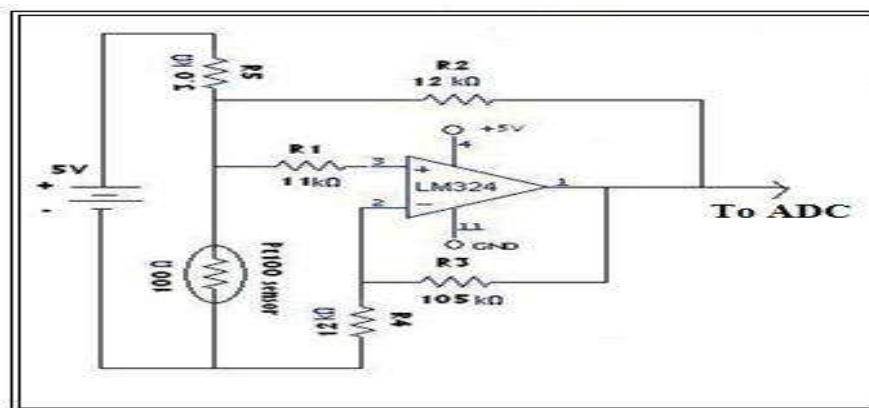

Fig.3. Signal Conditioning Circuit

ANALOG TO DIGITAL CONVERTER

Most of the physical quantities vary continuously, which is the characteristic of the analog world. Such a continuously varying quantity has to be invariably quantized in to digital format. This process calls for a

module that converts the analog quantity in to its equivalent digital value. This is accomplished using analog-to-digital converter (ADC). The ADC is used in the present work is International Journal of Electronics and Communication Engineering & Technology (IJECET), ISSN 0976 – 6464(Print), ISSN 0976 – 6472(Online) Volume 4, Issue 4, July-August (2013), © IAEMEAD574, which works on the principle of “successive-approximation technique”. The AD574 is a complete 12-bit successive-approximation analog to digital converter [5]. A high precision voltage reference and clock are included on-chip, and the circuit gives full rated performance without external circuitry or lock signals.

PLATFORM FLASH PROM

The Platform Flash PROM family provides non-volatile storage, easy-to-use, cost-effective, as well as an integrated bitstream delivery mechanism for use with target FPGAs [6]. The Platform flash PROM is used for the present work is XCF02S.

FIELD PROGRAMMABLE GATE ARRAY (FPGA)

FPGA design allows designers to design their own modules according to their needs and upgrade the system conveniently. The system design based on FPGA is flexible with the advantages of parallelism, low cost and low power consumption [7].

The target FPGA device is used in the present work is XC3S400-5PQ208 of Spartan3 family. Design development and debugging is carried on a low-cost, full-featured kit provided by Applied Digital Microsystems (ADM) Pvt., Ltd., Mumbai. This board provides all the tools required to quickly begin design and verifying Spartan3 platform designs. Designs are based on 10 MHz clock. The board includes a 1x16 pin connector, which can be used to connect a standard 5V character LCD module. LCD module can display 2 lines of 16 characters is made up of 5x8 Pixel.

III. CONFIGURATION OVERVIEW

CONFIGURING A DEVICE

FPGAs can be configured by using different modes like Boundary Scan, Slave Serial, or SelectMAP. The most commonly used mode is Boundary Scan, also known as JTAG (Joint Test Action Group). The Boundary Scan Register and other test features of the device are accessed through a standard interface - the JTAG Test Access Port (TAP). According to the standard, the TAP must contain four signals, TDI (Test Data Input), TDO (Test Data Output), TCK (Test Clock), TMS (Test Mode Select) [8]. When using this mode, the cable leads should be connecting to the following pins: TDI TDO, TCK, TMS, VCC, and GND. The JTAG port on the Daughter board is used to configure the FPGA and also to program the Platform Flash PROM. Parallel download cable is connected to the board through the JTAG port at one end and other end of the cable is connected to PC Parallel port. To work in boundary scan mode, pin1 and pin2 of mode selection jumper are shorted.

PROM File

Xilinx FPGAs are SRAM-based and must be programmed every time power is cycled. The most common method of programming Xilinx FPGAs is by using Xilinx PROMs connected to a chain of FPGAs as shown fig5. These PROMs must be programmed using PROM files created from the FPGA chain bitstreams. PROM files include information on the FPGA chain length and contain bitstreams that are reformatted for use with PROM programmers. Several PROM file formats are available: MCS, EXO, TEK, HEX, UFP, BIN, and ISC. In the present work FPGA is programmed using *.bit file and PROM is programmed using *.mcs file.

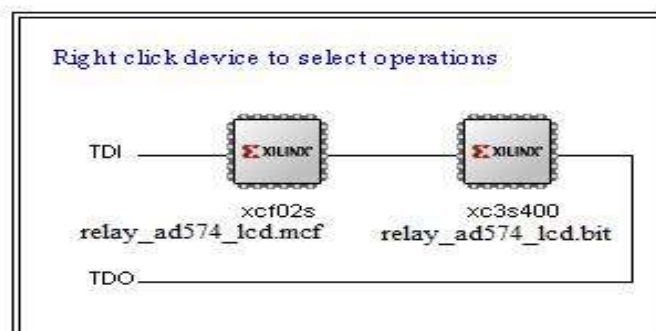

Fig.4. JTAG chain which shows the configured devices

IV. TEMPERATURE MEASUREMENT UNIT

The schematic of FPGA based temperature measurement and control system is shown in Fig.5 and the photograph of the FPGA based temperature measurement and control system is shown in Fig.6. RTD is inserted in the water bath; when the temperature of the water bath changes, then the resistance of RTD is also changes. The output produced by the RTD needs to be converted into quantized voltage levels. This can be achieved through a process known as “signal conditioning”. The signal conditioning circuit gives the analog voltage, which is proportional to the temperature. The signal conditioning may be a current to voltage conversion or simply amplification. The output of the signal conditioning circuit is fed to the AD574, since FPGA can process only digital data. AD574 converts the input analog voltage into 12-bit digital data. The graph drawn between temperature and digital output, which is a linear curve is shown in Fig.7. The Look- up table was developed using this curve. In order to initiate AD574, FPGA sends a high signal to R/C pin of AD574. The conversion starts when signal to R/C goes low. When the end of conversion signal of the AD574 is found to be high, it is an indication to the FPGA that 12-bit data which represents the temperature can be read in. FPGA compares the corresponding temperature value from look-up table and finally displays on LCD. The result is displayed in two lines as shown in Fig.8. The first line displays TEMPERATURE: and the second line displays the measured temperature value with first decimal and units as °C.

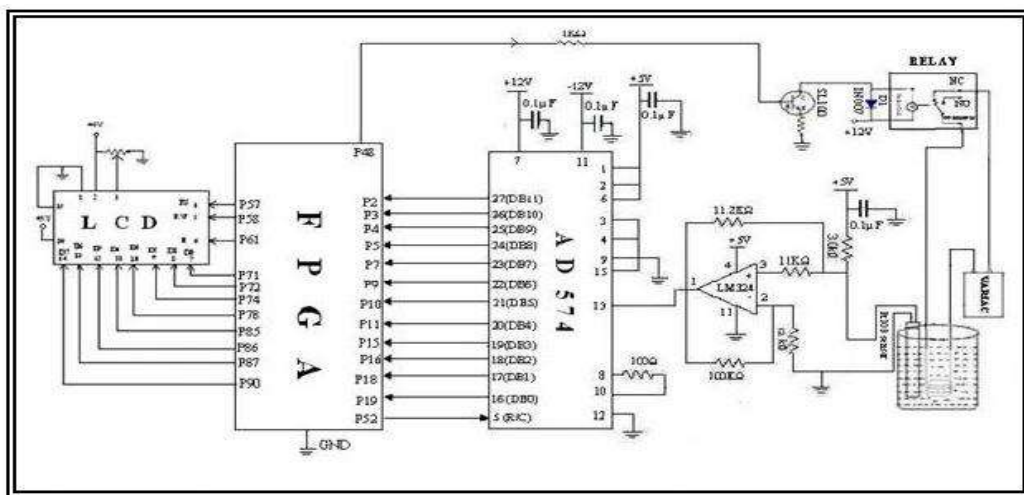

Fig.5. Schematic of FPGA based temperature measurement & control system



Fig.6. Photograph of the FPGA based temperature measurement & control system

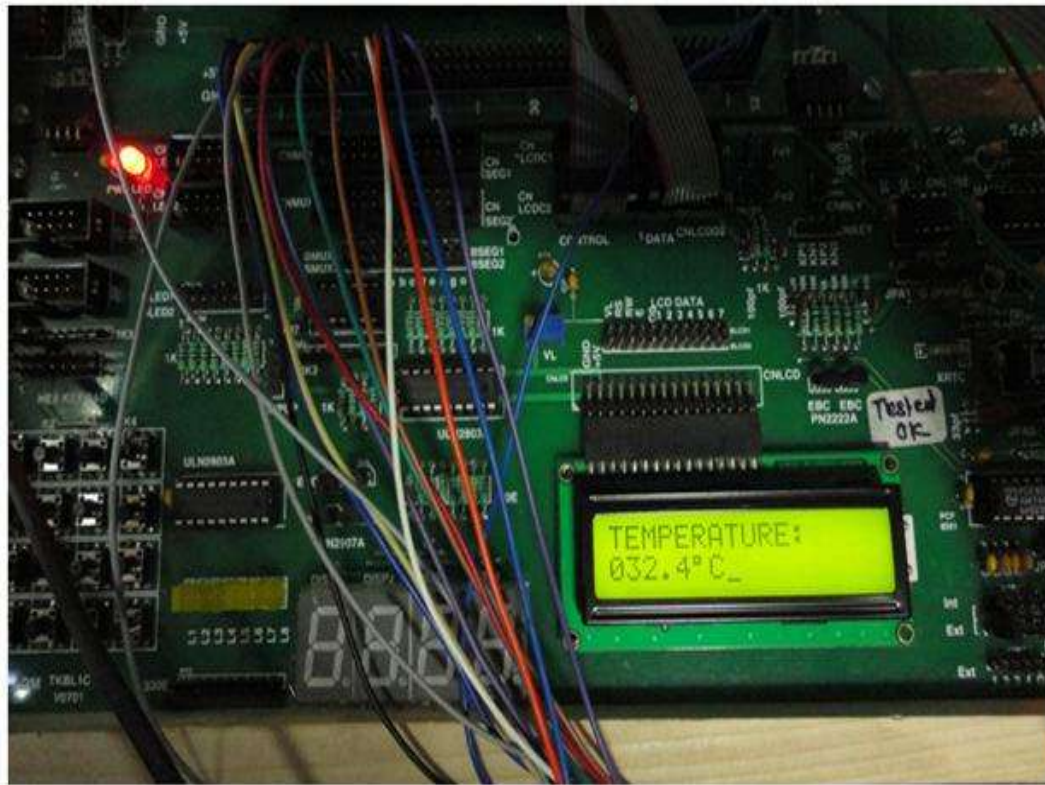

Fig.8. Photograph showing the results on LCD

V. TEMPERATURE CONTROL UNIT

The Electro Mechanical Relay is used to control the power delivered to the heater. A 240V AC powered immersion heater is controlled with this relay. To change the position of relay contact, a constant voltage should be applied across the relay coil. NPN transistor SL100 is used to control the relay with 12V coil, operating from +12V supply as shown in Fig.9. The photograph of the signal conditioning circuit, ADC and Relay unit is shown in Fig.10. A Series base resistor 1k is used to set the base current for SL100, so that the transistor is driven into saturation when the relay is to be energized. That way, the transistor will have minimal voltage drop, and hence delivering most of the 12V to the relay coil. Initially when the coil is not energized, there will be a connection between the common terminal and normally closed (NC) pin. But when the coil is energized, this connection breaks and a new connection between the common terminal and normally open (NO) pin will be established. A diode (IN4007) is connected across the relay coil, to protect the transistor from damage due to the back emf pulse generated in the relay coil's inductance, when SL100 turns off. That is, when the voltage is removed from the coil, it needs some path to discharge the stored energy in it. So the diode (IN4007) creates that path until the coil discharges [9].

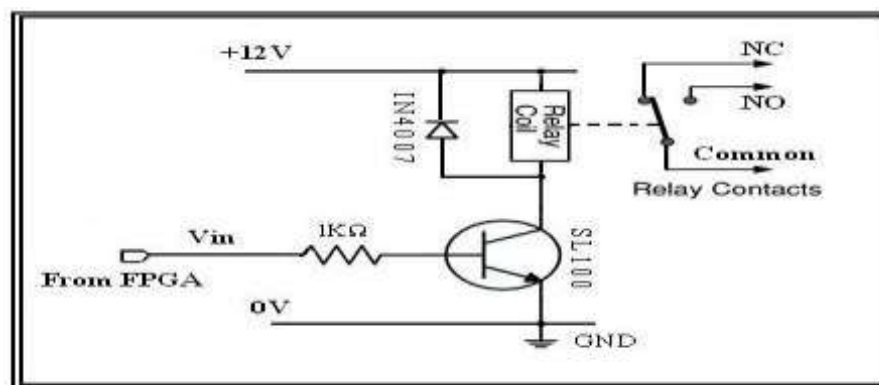

Fig.9. Electromechanical relay interfacing circuit

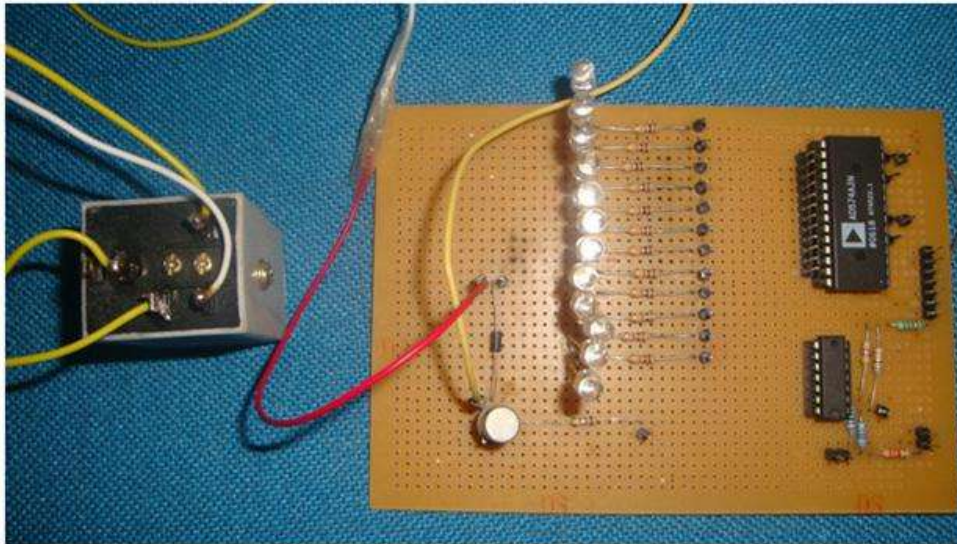

Fig.10. Photograph of the signal conditioning circuit, ADC and relay unit

The transistor on the input of the relay supplies the drive for the relay, isolates the FPGA from the relay and holds the relay in the NC position when the power is turned ON. The displayed temperature is compared by the FPGA with the set-point temperature. If it is less than the desired value, then FPGA sends a LOW signal to the relay interfacing circuit, so that the relay remains in the NC position. Hence the power is supplied continuously to the heater and the temperature increases [10]. If the desired temperature is reached, then FPGA sends a HIGH signal to the interfacing circuit, so that the relay contact shifts to NO position, which disconnects power supply to the heater. Thus the temperature is maintained at steady state and controls at a desired value. The flow chart of VHDL program for the present work is shown in Fig.11.

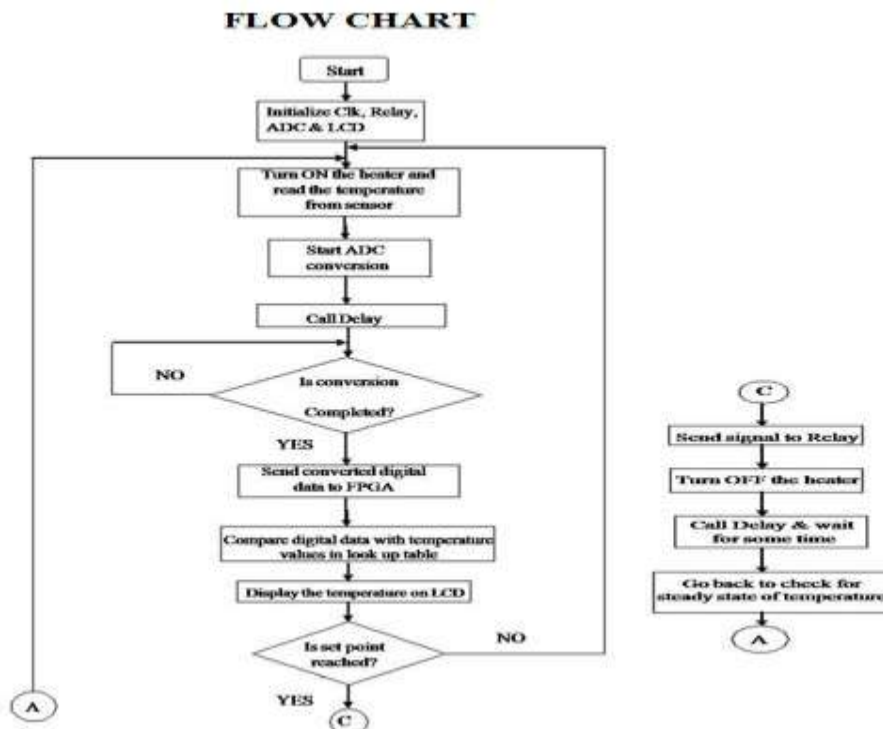

Fig.11. Flow chart of VHDL program for the present work

REFERENCES

- [1]. Daniel Hadji and Valentin S. Mollov, (2008) "Precise Temperature Measurement and Data Processing with Xilinx Spartan-3E Starter Kit", International Scientific Conference Computer Science', 219-24.
- [2]. Raghavendra Rao Kanchi, SreelekhaKande and RamanjappaThogata, (2008) "Design and Development of an Embedded System for Measurement of Temperature and Remote Communication using Fiber Optic Cable", Sensors & Transducers Journal, 99(12), 7-17
- [3]. Application Note 3450, <http://www.maxim-ic.com/an3450>
- [4]. K. Sreelekha, (2010) "Design and development of a microcontroller based measurement system for fluoride ion concentration using ion selective electrode", Ph.D. thesis, S.K.University, Anantapur, India.
- [5]. AD574 complete 12-bit A/D Converter Data sheet, Analog Devices.
- [6]. Platform Flash In-System Programmable Configuration PROMs [http:// www.xilinx.com/ support/documentation/ data_sheets/ds123.pdf](http://www.xilinx.com/support/documentation/data_sheets/ds123.pdf)
- [7]. Jayaram Bhasker (1998), "A VHDL Primer", 3rd edition, P T R Prentice Hall.
- [8]. JTAG Interface : Simple Introduction, www.amontec.com/pub/amt_ann004.pdf
- [9]. Relay Driving Basics, http://www.jaycar.com.au/images_uploaded/relaydrv.pdf.
- [10]. http://www.electronics-tutorials.ws/io/io_5.html.
- [11]. Prachi R. Shinde, Madhura Gad and Prof. S.U. Kulkarni, "Genetic Algorithm Approach into Relay Co-Ordination", International Journal of Electrical Engineering & Technology (IJEET), Volume 4, Issue 3, 2013, pp. 35 - 42, ISSN Print : 0976-6545, ISSN Online: 0976-6553.
- [12]. Bhavana L. Mahajan, Prof. SampadaPimpale and Ms.Kshitija S. Patil, "FPGA Implemented Ahb Protocol", International journal of Electronics and Communication Engineering & Technology (IJECET), Volume 3, Issue 3, 2012, pp. 162 - 169, ISSN Print: 0976- 6464, ISSN Online: 0976 -6472,
- [13]. M. A. Majed and Prof. C.S. Khandelwal, "Efficient Dynamic System Implementation of FPGA Based Pid Control Algorithm for Temperature Control System", International Journal of Electrical Engineering & Technology (IJEET), Volume 3, Issue 2, 2012, pp. 306 - 312, ISSN Print : 0976-6545, ISSN Online: 0976-6553.